



# TM4 SUMO™ MD Motor / Inverter System

## Features

- Peak power: Up to 265 kW
- Peak torque: Up to 3320 Nm
- Max operating speed: 3700 RPM

## Benefits

- High torque/low speed permanent magnet motor and inverter combinations
- Designed to interface directly with standard axles (no gearbox required)

## Standards

- System protection: IP67 / IP6K9K
- Automotive components: AEC-Q100/AEC-Q101/AEC-Q200
- Electromagnetic compatibility EMC: Main automotive international standards
- Shock and vibration standards: GMW3172 Sprung masses
- Max coolant inlet temperature: 65°C
- Coolant type: 40/60 water-glycol

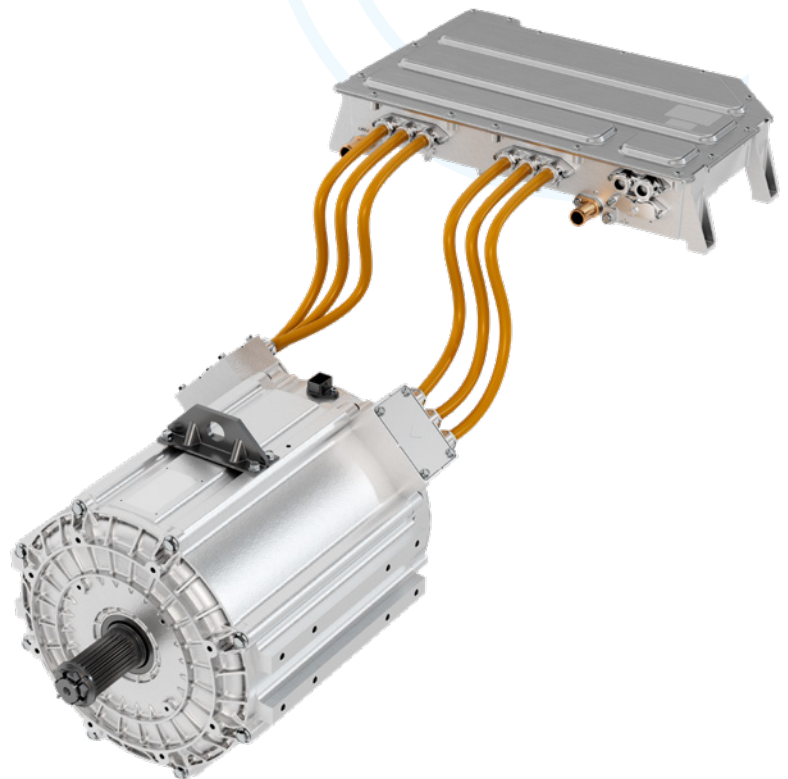

Ideal for Class 4 to 7 Commercial Vehicles, Bus Platforms, and Off-Highway Applications.

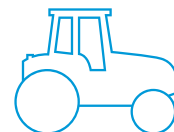
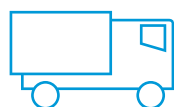

# TM4 SUMO™ MD Motor / Inverter System

The TM4 SUMO MD systems are designed to interface directly with standard axles (no gearbox required). It makes this series perfect for class 4 to 7 commercial vehicles, bus platforms, and off-highway applications.

## Motor Features

- Proven permanent magnet technology for optimal efficiency
- Outer rotor topology for maximum torque density
- Low electro-magnetic audible noise
- Low-cogging and ripple torque for better NVH
- Four-quadrant operation

## Latest System Features **NEW**

- Voltage increase: 750 V to 800 V
- Quick Connect with HVIL for safe and easy installation or maintenance
- Increased performances range
- KITAS option available on demand

## Inverter Features

- 3-phase or 6-phase high-voltage inverter
- Variable switching frequency
- Reflex™ gate driver technology for high power and current densities
- EMI Filter
- Best-in-class power density
- High efficiency

SYSTEM	CASING SIZE	INVERTER	PEAK POWER	CONTINUOUS POWER	PEAK TORQUE	CONTINUOUS TORQUE	MAX OPERATING SPEED	VOLTAGE RANGE
SUMO MD MV2500-6P*	L2	CO200	230 kW	115 kW	2500 Nm	1140 Nm	3000 RPM	130-450 Vdc
SUMO MD HV1800-3P	L1	CO150	170 kW	100 kW	1775 Nm	680 Nm	3250 RPM	300-750 Vdc
SUMO MD HV2200-3P	L2	CO150	215 kW	145 kW	2430 Nm	1275 Nm	2700 RPM	300-750 Vdc
SUMO MD HV2200-3P** <b>NEW</b>	L2	CO150	200 kW	145 kW	2200 Nm	955 Nm	2700 RPM	300-800 Vdc
SUMO MD HV2200-6P	L2	CO200	255 kW	190 kW	2355 Nm	990 Nm	3700 RPM	300-750 Vdc
SUMO MD HV2400-6P	L1	CO200	240 kW	120 kW	2300 Nm	605 Nm	3500 RPM	300-750 Vdc
SUMO MD HV2600-6P	L2	CO200	265 kW	155 kW	2760 Nm	970 Nm	3500 RPM	300-750 Vdc
SUMO MD HV2800-6P** <b>NEW</b>	L2	CO200	300 kW	180 kW	2860 Nm	1050 Nm	3500 RPM	300-800 Vdc
SUMO MD HV3000-6P	L2	CO200	235 kW	145 kW	3100 Nm	1055 Nm	3000 RPM	300-750 Vdc
SUMO MD HV3300-6P** <b>NEW</b>	L2	CO200	235 kW	130 kW	3320 Nm	960 Nm	3000 RPM	300-800 Vdc

600 Vdc, 45°C / \*350 Vdc, 45°C / \*\*650 Vdc, 45°C  
Specifications are subject to change

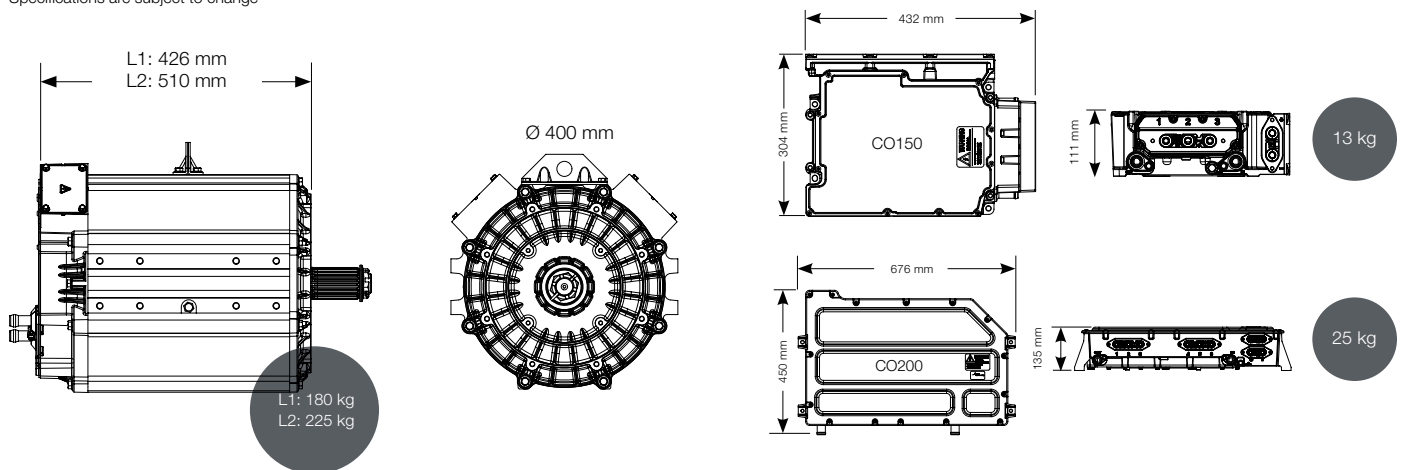

[Dana.com/TM4](http://Dana.com/TM4)

### Application Policy

Capacity ratings, features, and specifications vary depending upon the model and type of service. Application approvals must be obtained from Dana TM4; contact your representative for application approval. We reserve the right to change or modify our product specifications, configurations, or dimensions at any time without notice.

